



Paving the way

HTS

STAINLESS STEEL SPREADERS

Ideal for heavy-duty municipal commercial applications

- Self-contained hopper.
- Spreads free flowing materials sand and/or salt.
- Spread width of 1-13 m.



3...13 m³

HillTip Oy Ab
Pukkisaarentie 6
FIN-68600 Pietarsaari
Finland

Tel. +358 (0) 505983026
Tel. +358 (0) 503659415
Fax +358 (0) 6 724 36 06

www.hilltip.com
info@hilltip.com

HTS Stainless steel



Inverted "V" prevents material compaction and reduces wear on drive train components.

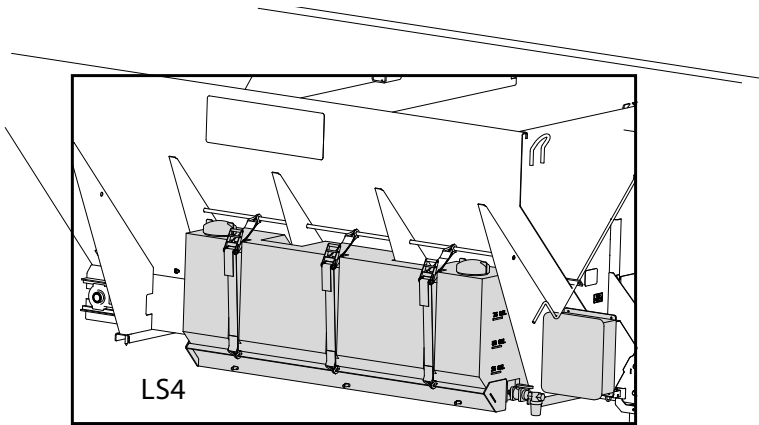

Optional Equipment: Liquid Spray System

GENERAL – Completely self-contained, ultra durable spreader unit designed for ice and snow control. The rugged design allows for use with salt, sand and other materials. The complete assembly mounts easily on pickup, dump and platform trucks making it ideal for municipalities, shopping malls, industries, hospitals and private contractors.

ELECTRIC MOTORS – Two ultra-quiet 12-volt DC direct-drive motors power the conveyor and spinner, and are encased in a heavy-duty housing. The wiring harness is constructed of 10-gauge automotive wire with non-combustible sheathing (-50°C to -105°C). An in-cab console features independent controls for the conveyor and spinner.

STAINLESS STEEL MATERIAL HOPPER – Electrically welded high-quality grade 304 stainless steel ends and sides sloped at 45° are constructed with channel formed top edges. 304 stainless steel vertical supports add extra strength to the unit. The single lift point on the cross support beam is located at the unit's center of gravity to allow for easy loading and unloading. The floor is constructed of 304 stainless steel.

CONVEYOR – The conveyor is made of 30 cm wide all-steel pintle chain with 5 mm x 20 mm cross bars. Chain strength is 5.000 kg per strand; 10.000 total weight. The drive sprockets are 6-tooth cast iron, on a 28 mm diameter shaft. The conveyor chain has an adjustment range of 9 cm. The drive shaft has heavy-duty, sealed, self-aligning ball bearings with grease fittings. The idler drum has heavy-duty 2,5 cm diameter ball bearings.

FEEDGATE – Lever operated with a friction lock for accurate adjustment.

SPINNER CHUTE ASSEMBLY – A 29 cm polymer disc with four fins is connected to a 2 cm diameter shaft secured on the pillow block and motor bearing. The spreading material is guided from the conveyor to the spinner plate through an enclosed high-quality grade 304 stainless steel chute with internal and external deflectors. Adjustable deflectors allow for complete directional spread control and full or compact spread. Total spread radius ranges from 2' to 30'. The extra wide rear deflector protects the rear and under carriage of the vehicle.

Model	Hopper Length	Overall Length	Width	Height	Empty Weight	Capacity m ³ (water level)	Capacity m ³ (rounded)	Spreading Wideness
HTS4500SS	305	365	215	145	975	4,5	5,0	1-13 M
HTS5500SS	305	365	215	145	1050	5,5	6,5	1-13 M
HTS6500SS	365	425	210	145	1400	6,5	7,5	1-13 M
HTS8000SS	365	425	210	160	1485	8,0	9,0	1-13 M
HTS8000SSX	425	485	210	145	1670	8,0	9,0	1-13 M
HTS9000SS	365	425	210	175	1475	9,0	10,0	1-13 M
HTS9500SS	425	485	210	160	1750	9,5	10,5	1-13 M
HTS10500SS	425	485	210	175	1800	10,5	13,0	1-13 M